

Keynote: Concertgebouw Amsterdam: History of the main hall and its acoustics; PART 2: Preserving the acoustics

Martijn VERCAMMEN¹; Margriet LAUTENBACH²; Rob METKEMEIJER

Peutz, The Netherlands

ABSTRACT

After the difficult first decade, the Amsterdam Concertgebouw became famous and the acoustics of the hall became something to be preserved. As most buildings in Amsterdam, the Concertgebouw is built on a wooden pile foundation. At the end of the seventies the foundation appeared severely undermined. Unequal setting of parts of the foundations resulted in cracks in the Brickwork. A national rescue operation was set up, executed and finished in 1988. A new concrete pile foundation was made under the existing building and a new basement was created. The normal concert program continued during these works. The main goal during this first part of the renovation was to preserve the famous acoustics of the hall.

After the big renovation, the interior of the concert hall and the rest of the building was renovated stepwise. Modifications included the change of the ceiling, the replacement of the wooden floors, new seats and modified seating plan on the balcony. Preservation of the acoustics continued to be the prime target.

1. Period 1900-1980

After rebuilding the stage and solving the logistics, with a sufficient number of audience members and a chief conductor who was able to cope with the hall's acoustics, the hall, the orchestra and its conductor became famous. Mengelbers' dedication to composers such as Gustav Mahler, Richard Strauss and Igor Stravinsky made him and the orchestra very well known. The orchestra travelled to many European cities and all prominent European musicians performed in the Concertgebouw. The acoustics of the hall became its prime quality, something to be protected and preserved. No significant changes were made to the hall, but nevertheless several minor changes happened.

To cut costs, the hall was painted white in 1888. In 1898 the hall was painted with colours.

In 1900 the seats were fixed to the floor, as ordered by the fire brigade, enlarging the row distance. It reduced the capacity of the hall to 1750 seats (not including seats at stage). The seating is shown in Fig. 1.

In 1913, the 25-year anniversary was an inspiration to make new plans to solve the shortage of audience space. A design was made with two intermediate balcony levels and loges at the ground floor and an extension of the existing and new balconies until the organ. The capacity could be increased from 1750 to 2726. The plan was not received very well and the new situation of the First World War gave it a final blow. This is fortunate because it would probably have destroyed the excellent acoustics.

Somewhere in this period the stage was altered to accommodate audience seats on stage.

In 1938 the seats on parterre were replaced with more comfortable seats with more absorption, especially when unoccupied (fig.1).

In 1947 it was discovered that the wooden floor construction was damaged by perennial fungus. A new floor construction was made with concrete, 40 mm of sand and a new wooden floor above this (fig. 1). Of course this was a risky operation, as it could change the low frequency absorption of the floor. Apparently after this change, the hall was as good as before, maybe even better (5).

In 1950 some small changes were made to the stage. The slightly sloped floor was made flat to enable dance/ballet performances and an orchestra foyer was built under the stage.

In 1954 the roof dormers were renewed (see par.5.1). In 1957 the now famous stairs of the stage were made. It takes quite a long time to get on stage, especially with a long dress.

¹ m.vercammen@peutz.nl
² m.lautenbach@peutz.nl

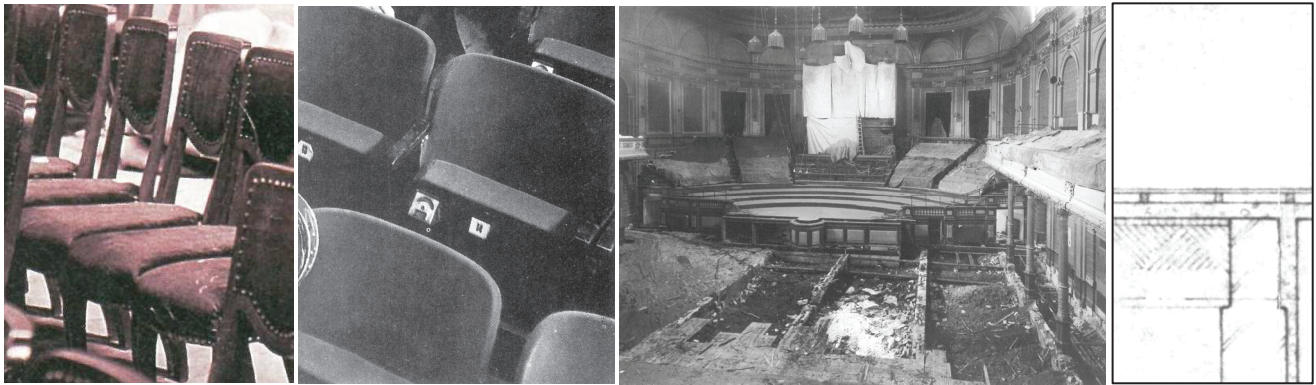

Figure 1. From left to right: original seats, seats in 1938, renewal of the floor in 1947, section after renewal

Due to the unequal setting of the building (see paragraph 2.1), bits and pieces from the ceiling ornamentation were coming off now and then. After a falling piece of stucco narrowly missed a musician during rehearsal of Tchaikovsky's Overture 1812, it was decided to remove them all. In 1962 the lists and rosettes were removed and the middle rosette was reshaped into what was nicknamed a flower pot, see fig. 7 and 8. This was, as far as we are able to determine, the first time acoustical advisors were consulted (Philips and TNO Delft). Since then, the ceiling has been a point of attention and vibrations were monitored on several occasions, for example during pile driving in the neighbourhood.

During that same period, the remaining old seats against the side walls, on the balcony and on stage were replaced by the new design (of 1938) and the fabric of the other seats was renewed in 1966. This must have added absorption on stage, especially when the seats were not occupied.

Related to the 80-year anniversary in 1968, it was possible to raise funds for a refreshment of the interior. In 1970 the stucco of the walls was repaired and the painting, still from 1898, was redone as well as the curtains for the doors (portières). The stage front, which was changed many times, was restored using old pictures and some modifications of the stage were executed.

In 1981, 1300 seats on the ground floor were renewed, these were copies of the seats from 1938. The seat number was reduced from 2169 to 2089.

2. RENOVATING THE CONCERTGEBOUW

2.1 The hall is sinking

There is a well-known Dutch children's rhyme that goes: "Amsterdam that big town, is built on a hundred piles, if it would fall over, who is going to pay?"

At that time it was common for foundations to be made of wooden piles driven into the soft soils. These foundations can hold for very long, provided the wood remains under the ground water level. The foundation of the Concertgebouw consists of pairs of wooden piles, connected by a capping, see fig. 2 left.



Figure 2. The wooden piles with capping under the building and the cracks in the walls

The first reports on irregular settings are from 1903. The probable cause indicated was the extreme sound levels on the round corners of the hall (!). These round corners do not have their own

foundation, but are supported by the foundation under the rectangular walls.

In 1931 popping sounds were heard, “though there was no hail”. In 1954 the damage due to the sinking of the walls of the hall led to renewal of the roof dormers.

Around 1976 they started monitoring to investigate the sinking of the walls. In 1983 the alarm bells started ringing. The difference in setting was 18 cm and the speed of (unequal) sinking was such that short-term renovation of the foundation was necessary.

There were multiple reasons for the sinking. The load of the walls of the hall was higher than that of the other walls and was further increased by the introduction of the heating system from Leipzig, by doubling the walls after the piles were already driven into the soil. Moreover, some piles were not driven deep enough and there might have been variations in ground water level in the 19th century.

2.2 How the building was saved

As indicated in the children’s rhyme, renewal of the foundation would be a costly matter. In fact, 35 million Dutch guilders (16M€) were needed. A national fundraising action was started and coupled with the upcoming centennial celebrations in 1988. Many companies contributed and more than half of the funds came from non-governmental organisations.

Apart from the renewal of the foundation, the goals for the renovation were to enlarge the foyer spaces, renew the installations, improve the climate in the halls (ventilation) and improve working spaces for musicians and personnel. A new basement was built as well as a new side wing building.

The new foundation was made with a specially adapted machine. The ground under the hall was removed until just above the cappings of the wooden piles. On both sides of the existing foundations, steel pipes of 1.8 metres were screwed into the soil. After it was driven into the soil, a next steel pipe segment was welded onto it and so forth, to a total length of about 18 m. Only in the main hall a short holiday break was used to drive in much larger elements from above the floor of the main hall itself (fig. 4).

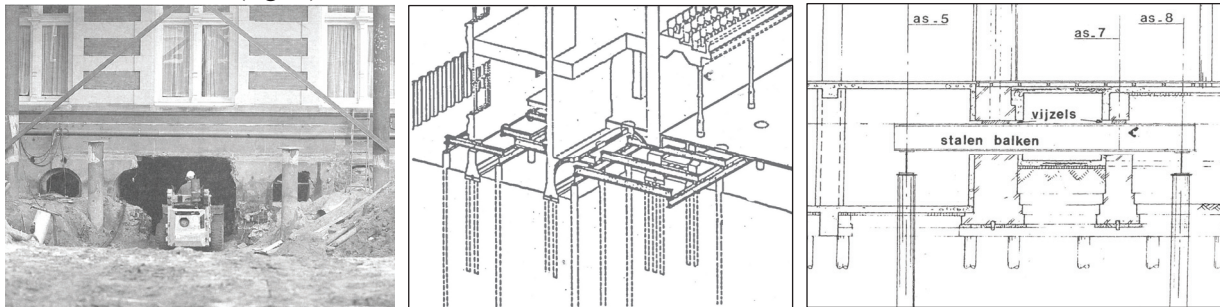

Figure 3. Renovation of the foundation (Strukton)

After filling the steel pipes with concrete, steel beams were made through the existing foundation and supported by the new piles. These beams were then raised to support the old building (fig.3). After the whole building was supported by the new piles, the existing foundations were removed and a new basement was made, cutting the new piles at the right height.

The renovation was going to be completed in stages. During the renewal of the foundation and construction of the basement, both rehearsals and concerts in the main hall were to continue as much as possible. The building method caused relatively little noise and vibration annoyance; only during a short period did the orchestra need to rehearse elsewhere. A temporary two-storey building was made as a foyer space. The carpet in the hallways around the hall was rolled up when the workers started after the concert and rolled out again just before the next concert.

2.3 Nothing to be changed in the hall

The acoustics of the main hall was and is considered to be the crown jewels of the building. Peutz was appointed as acoustic consultant. Both Peutz and the Concertgebouw were of the opinion that the main hall should be excluded from the first phase of the renovation; at least no visual changes should take place during the first renovation phases (9). Any criticism of the changes in the main hall could potentially jeopardise the progress of the urgent renovation. Nevertheless, a few things, which were related to the room acoustics, needed to be done:

The concrete floor from 1947 with sand on top of the concrete was maintained. From the new basement, this existing concrete floor was supported with a steel construction. A few phases earlier, the steel piles were driven in through this floor. The holes in the floor were closed again, to make it as it was. A gypsum board ceiling was added below the concrete floor.

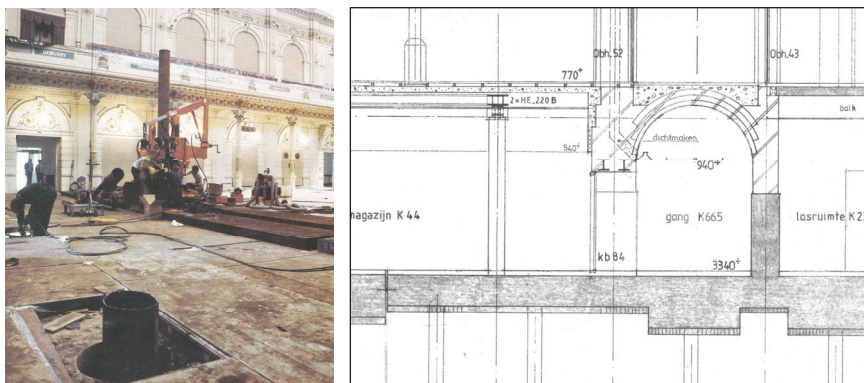

Figure 4. Left: Pile drilling in the main hall (2), right: section of the new situation

Both the use of new rooms in the basement as well as the use of the existing spaces around the hall should not cause any disturbance in the main hall. Nevertheless, there is only one building structure. After all airborne sound transmission paths are reduced, the sound insulation between the small hall and main hall is limited by structural sound paths.

The hall did not have a ventilation system. In the early years, there was not even a wardrobe and people brought their wet clothes into the hall. In 1898 a satirical poem about the suffocating air in the hall was published (5). The hall was ventilated after each performance, but with the increasing number of performances, the need for better air quality in the hall was evident. An air handling system was developed with air nozzles high up in the side walls. The air inlets were connected to plenum boxes that are installed in the attic spaces adjacent to the hall. The acoustic requirement was a sound level of NR15/20 dB(A) in the hall, based on measured background noise. The air system was optimised in the Peutz acoustics laboratory. The 14 plenum boxes of 1780 m³/h each got two connections to the air supply at opposite sides to achieve equal air quantity through all nozzles (fig.5). The measured sound power per element was only 26 dB(A).



Figure 5. Left: Air inlet system in 1988; Middle: Air inlets after 1998, right: Air handling in the towers

No equipment was allowed near the hall, to minimise risk, also in case of malfunction. Air handling units for supply and exhaust air were installed on new, resiliently mounted, concrete floors in the four towers of the building. Cooling and heating were installed in a separate building. Air extraction from the hall is done through the lighting and stage scenery openings in the ceiling. The attic space acts a big return air plenum, and the roof was thermally and acoustically insulated.

To be able to verify that the acoustics of the main hall had not changed, measurements were taken before the renovation. The measurements included reverberation times, decrease with distance of the sound from a point source, and measurements of the impulse response with Time Delay Spectrometry (TDS), using a TEF analyser. This was a technique that became available shortly before this renovation. Recordings with an artificial head were also made for subjective evaluation.

Although insuring the acoustics was considered, in the end this was not done (2). Floppy disks with measurement data taken before the renovation were stored in a safe, so as to have a clear starting point in case any discussion may arise. Luckily, there was no discussion...

For fire safety reasons, exit doors on the side balcony needed to be added. To have these doors in a better position, enlarging the side balconies to the front by 5-8 m was investigated. A mock-up was made and measurements were taken. It was decided that the acoustical difference was too significant. Fortunately, another solution was found for the doors.

2.4 Renovating the main hall

Ten years after the big renovation and the centennial celebrations, it was the main hall's turn to be renovated. This renovation included an upgrade of the hall's finishing and a change of the ceiling. Additionally, some technical issues were addressed, such as the holes in the ceiling and the heating/convection elements at the side walls.

The upgrade of the finishing included the gold plating of parts of the ornamentation and painting the hall with brighter colours and a much glossier paint. In terms of acoustics, it is very difficult to compare the sound absorption of very low absorbing materials, especially with on site measuring techniques. Thus, the existing surface was studied using microscopy and samples of the existing surface were compared with the new paint. The existing paint showed to be a very closed layer, so it was concluded that no changes in sound absorption were to be expected.



Figure 6. Gold plating of the ornamentation (9)

The cassettes in the ceiling had lost their original ornamentation in 1962. In 1998 this was brought back; it was partly original (with the original moulds), partly a new interpretation. The centre elements (called “flower pots”) were given a new ornamentation (nicknamed “lettuce crops”). The supporting construction was changed resulting in a small increase of surface mass.

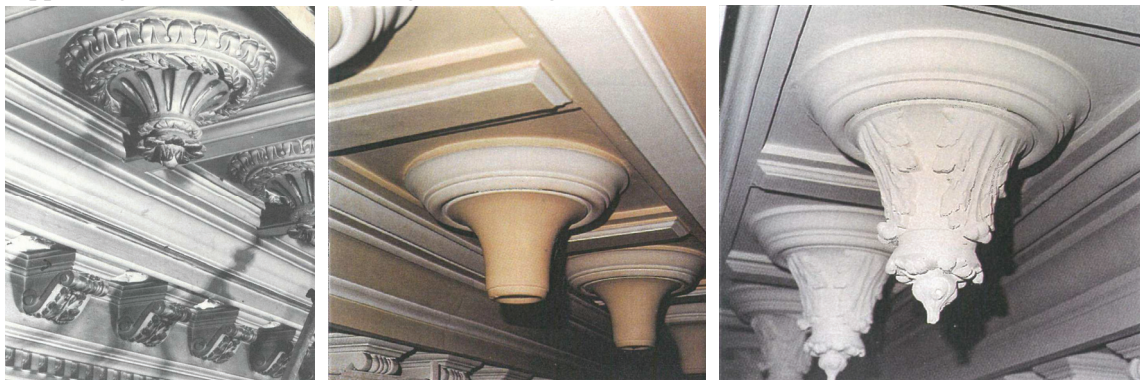

Fig. 7. Ornamentation edge of ceiling, Left: original; middle: 1962, right: after renovation 1998 (9)



Fig. 8. Ornamentation of ceiling, Left: original; middle: 1962, right: after renovation 1998 (9)

The effect of the change was expected to be very small. The requirement regarding reverberation time was that changes should remain within ± 0.1 s. which corresponds to about 50 m^2 of absorption. To be sure that it would not cause a measurable or audible change, a 1:1 scale model was made (fig.9) and tested in the Peutz Laboratory. Arup Acoustics was asked to give a second opinion.



Figure 9. Left: A sample of the ceiling cassette in the laboratory and right: during construction

The influence of the added ornamentation and the new layer of paint was tested, in respect to sound absorption and sound scattering to 10 fixed microphone positions.

The sound absorption remained unchanged (≤ 0.01); only at 63 Hz octave band was the absorption coefficient reduced by about 0.02, which is smaller than the repeatability in this frequency band (which is below the lower frequency of 100 Hz in the ISO 354).

There were a number of other, minor changes in the hall, such as new stage fronts behind the staircases to the stage, the renewal of the carpet at some positions and repair of detached stucco. These changes were evaluated based on calculations of their influence on the reverberation time. The increase in weight of the ceiling due to the added ornamentation caused a minor decrease in low frequency absorption, which was compensated by the increase of the number and the diameter of the holes in the ceiling (from $\varnothing 70$ to $\varnothing 110$). The holes in the ceiling were changed, to create a more regular pattern, but also to increase the lifting possibilities in the hall.

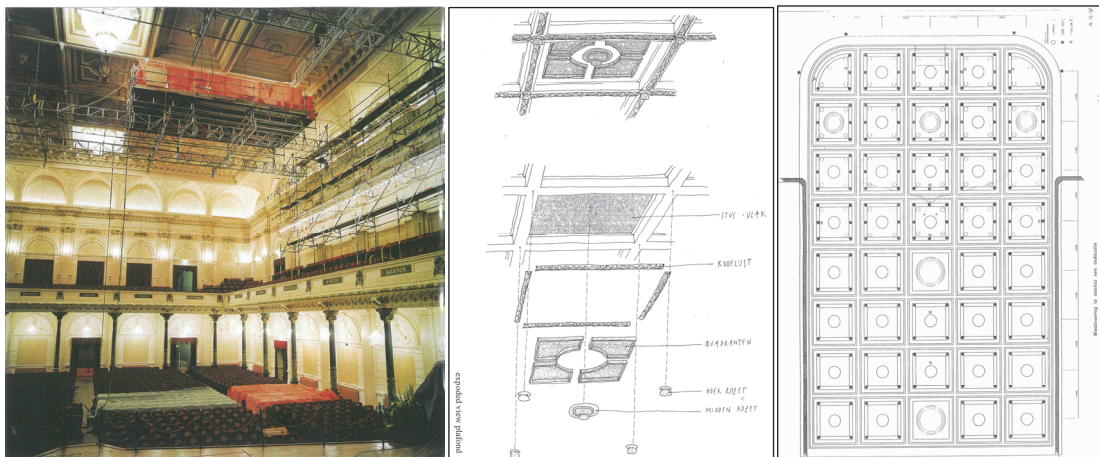

Figure 10. Left: The main hall in 1998 during renovation (8), Middle: Changes to the ceiling and Right: new ceiling plan with hoist openings (9).

In total, the changes were predicted to have a negligible effect on reverberance. Only a slight increase of reverberation time at high frequencies was expected, due to the cleaning of the hall (removal of dust). This is expected to be a temporary effect, but it might be noticeable, also because this perception will be supported by the brighter colours of the hall.

The capacity of the air inlet system was increased from 24,000 to 35,000 m^3/h , and the nozzles were replaced by much larger cylindrical tubes. At the bottom of the walls, heating/ventilation units were placed. The larger holes in the ceiling enabled increased exhaust without increase of air velocity.

Again this renovation was performed with the hall in use. A scaffold was built on top of the side balconies and connected by a bridge construction under the ceiling (fig.10). There was even a CD recording made in this situation. The work was done within four months time and mostly at night. (9) .

In 1994 the seat cushions were renewed and five years after renovating the hall, in 2003/2004, this renovation was finalised with the replacement of the seats (fig. 11). They were a copy of the seats from 1938/1981, see also paragraph 3.1. The number of seats was slightly reduced because of increased row distance. At the balcony both row distance and height differences were increased. The increase of absorption by the modified seating arrangement on the balcony was calculated to have an

influence on the reverberation time of less than 0.01 s.



Figure 11. Seats before (left two) and after exchange (right two) in 2004.

Furthermore, the floor in the hall was replaced and in 2007 the stage floor was renewed. For these changes thickness, weight, and bending stiffness were compared to the existing floor.

3. SOME REMARKS ON THE ACOUSTICS

3.1 The reverberation time of the main hall

The reverberation time RT of the main hall has been measured many times. Some available data are presented in fig. 12 (left), for the unoccupied situation, but with seats.

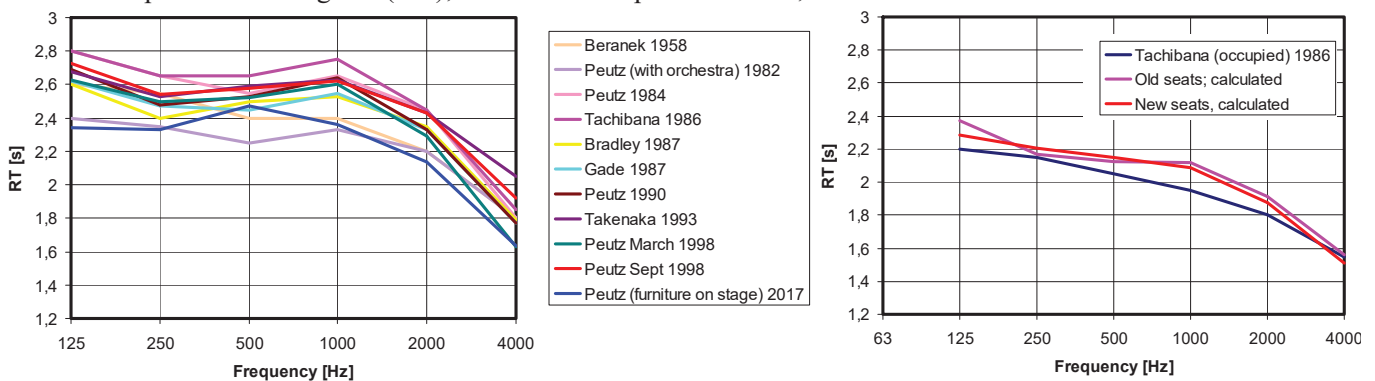

Figure 12. RT in the Concertgebouw, a.o. from (6) and (11), left: unoccupied, right: occupied

Most of the data falls within a certain bandwidth, which may result from different settings in the hall, but may also be due to different measurement techniques, positions in the hall etc. (see also par. 3.2). Some interesting results:

- The 1982 measurement shows a significant influence from the orchestra.
- The measurements just before and just after the renovation of the hall in 1998 show no change in the octave bands 250 - 1kHz. At 125 Hz an increase of slightly less than 0.1 s. is measured. At 2 and 4 kHz an increase of 0.1-0.2 s. was measured. This was expected to be a temporary effect due to cleaning the hall.
- The 2017 measurements show a shorter RT in the unoccupied situation. This is due to the furniture on stage (previous measurements are with an empty stage except for the 1982 measurement) and increased sound absorption of the seats in the unoccupied situation. Laboratory measurements on the existing and new seats in 2003 showed more or less the same absorption in the occupied situation but an increase of absorption in the unoccupied situation.

Fig. 12 (right) shows RT in the occupied situation. One available measurement is shown along with calculated RT in two situations:

- the calculated RT in the situation before replacement of seats, based on the measured RT in September 1998 and the laboratory measurements of the old seats with and without audience;
- the calculated RT in the situation after replacement of seats, based on the measured RT in 2017 and the laboratory measurements of the new seats with and without audience.

The calculated RT's in the occupied situation before renovation and after replacement of seats are very similar and slightly longer than those obtained in 1986 by (6) (RT obtained from last notes a music recording). The increased absorption in the unoccupied situation is beneficial for rehearsals,

though the effect will be limited. During rehearsals of the Concertgebouworkest, a large curtain is usually hung in the middle of the hall, to reduce the reverberance.

An estimation of RT in the situation just after opening, with a small orchestra and a small audience (for example 300 people), leads to a reverberation time of around 4 s. No wonder the hall was experienced as excessively reverberant in this situation. It is clear that sound-absorbing seats and the presence of a sufficiently large audience are essential to keep the acoustics within reasonable boundaries.

3.2 The impulse response

In general, the impulse responses in the Concertgebouw are very regular. Even reflections from surfaces that could be considered dangerous, such as the rear wall reflection, do not significantly protrude in the response. At many positions, the hall shows an abundance of early energy.

Many impulse responses, such as those presented in fig. 13, show a steady level of reflections, a plateau during the first 0.2 s that is assumed to be perceptually important, and only after this period the decay seems to start.

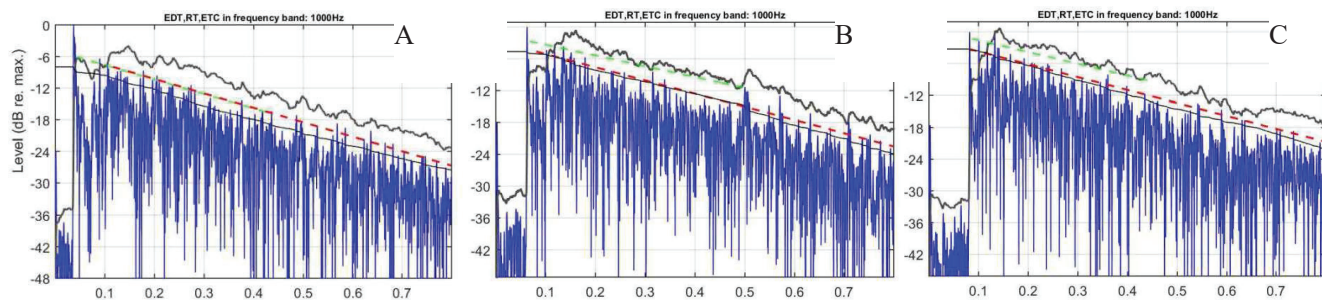

Figure 13. Energy Time Curve 1kHz oct., from Stage front right side (Celli) to: A. parterre left side, distance ca. 12 m, B. parterre left side, distance ca. 21 m, C. rear balcony left, distance ca. 27 m; Black line: smoothing 20 ms. Omnidirectional point source and an MLS signal.

It is interesting to note that the reverberation time is calculated over the decaying part of the curve. The plateau, which could be considered as a “delay” of the decay curve, is not considered.

4. CONCLUSIONS

The Concertgebouw’s early acoustical difficulties involved an interrelationship of musical, architectural, and social factors. The problem with the orchestral balance was solved by changing the stage. The excessive resonance was reduced by the increasing number of audience. The introduction of absorptive seats and the use of the choir places on stage for audience in later years must have contributed as well. In later years, the focus was on how to preserve the acoustics of the hall, especially during the renovation period from 1985 to 2004.

REFERENCES

1. Lydia Lansink, De akoestiek van het concertgebouw historisch bezien, 90 jaar Concertgebouw en Concertgebouworkest, Praeludium, April 1978
2. B. de Vries, Geen slotaccord voor het Concertgebouw, Nieuwsblad Nationale Nederlanden, december 1985
3. Renovatiejournaal, bijlage bij Praeludium, oktober 1986
4. Lydia Lansink, Het Concertgebouw, een drang tot hoger leven, in Historie en kroniek van het Concertgebouw en het Concertgebouworkest deel I, Voorgeschiedenis 1888-1945, Walburg pers, 1989
5. Lydia Lansink, Het Gebouw: functie en vorm, en Het Gebouw: draagkracht en draaglast, in Historie en kroniek van het Concertgebouw en het Concertgebouworkest deel II, 1945-1988, Walburg pers, 1989
6. H.Tachibana, Y.Yamasaki, M.Morimoto, Y.Hirasawa, Z.Maekawa, C.Posselt, Acoustic survey of auditoriums in Europe and Japan, J.Acoust.Soc.Jpn.(E)10,2(1989)
7. J. Rubinstein, Renovatie Concertgebouw, flyer 1984
8. Nachtelijke restauratie op hoog niveau, Mebest, 1998
9. E. van der Hoeven, De renovatie van de grote zaal van het Concertgebouw Amsterdam, Merckx + Girod, 1999
10. H. Posthuma de Boer, Concertgebouw en Koninklijk concertgebouworkest Amsterdam, 2003
11. L.Beranek, Concert halls and opera houses, Springer-verlag, New York, 2004